

PEH 526 / 626

RoHS
Compliant

- Designed for automotive applications
- Temperature rating 125 °C
- Resistance to vibrations
- Low ESR, High ripple current capability

APPLICATION

A high performance electrolytic capacitor designed for automotive applications with high vibrations and high ambient temperatures.

BASIC DESIGN

An electrolytic capacitor with outstanding electrical performance. It is polarized with the negative pole connected to the case. The outer case has a plastic cover. The low ESR is a result of a low resistive

electrolyte/paper system. Together with the TDC thermal concept, this range has very high ripple current capability. The capacitor is suitable for both mobile and aircraft applications, with operation up to 125°C.

SPECIFICATION

Standards	IEC 60384-4 Long Life Grade 40/125/56 In accordance with CECC 30 301-809
Capacitance range	820-6800 μ F
Capacitance tolerance	-20 to +20%
Rated voltage	25-63 VDC
Temperature range	-40 to +125°C
Leakage current, I_{RL} (μA)	$0.01 (\mu A) \times C_R (\mu F) \times U_R (V)$
Operational life time	4000h at 125°C, 20 000h at 105°C
Shelf life	0V +105°C 5000 h, +40°C 10 years
Diameter range	22 - 30 mm
Resistance to vibrations	10 - 2000 Hz, 1.5 mm displacement amplitude or max. 20 g 3x2 hours. The capacitor shall be clamped by their body.
Life test	4000h, 125°C

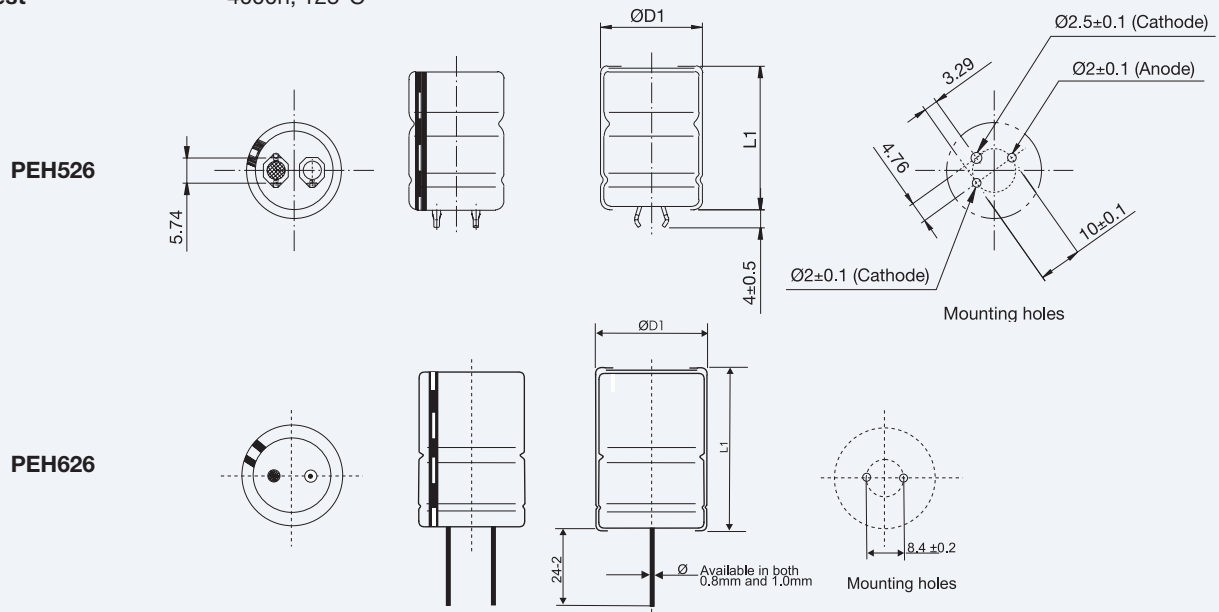

Dimensions table (mm)

D x L	Case code	D1 ± 0.5	L1 ± 1.0	Weight approx (g)
22 x 25	AB	22	26	12
22 x 30	AC	22	31	14
25 x 25	BB	25	26	19
25 x 35	BD	25	36	24
30 x 25	CB	30	26	24
30 x 35	CD	30	36	34

Pin Configuration

Description	3 pin snap-in	radial lead $\varnothing 0.8$ mm	radial lead $\varnothing 1.0$ mm
Pin length	4.0 ± 1	24 ± 2	24 ± 2
Code	3	08	10
DIA. mm -0+1			
22	•	•	•
25	•	•	•
30	•	•	•
35	•	•	•

ARTICLE TABLE PEH 526 / 626

C_R	D x L	I_{RAC}^* 125°C 100 Hz	I_{RAC}^* 85°C ≥5 kHz	I_{RAC}^* 105°C ≥5 kHz	I_{RAC}^* 125°C ≥5 kHz	ESR* 20°C 100 Hz	ESR* 20°C 100 kHz	ESR* 125°C ≥5 kHz	Article code	Pin configuration
μF	mm	A	A	A	A	mΩ	mΩ	mΩ		
25 VDC (U_R)										
2700	22 x 25	2.0	9.7	7.4	3.7	54	30	14	PEH - 26HAB4270M--	
3900	22 x 30	2.5	11.9	9.1	4.5	38	22	10	PEH - 26HAC4390M--	
3900	25 x 25	2.3	10.1	7.7	3.8	41	24	14	PEH - 26HBB4390M--	
5600	30 x 25	2.7	10.2	7.8	3.8	33	22	17	PEH - 26HCB4560M--	
6800	25 x 35	3.4	14.4	11.0	5.5	24	14	9	PEH - 26HBD4680M--	
40 VDC (U_R)										
1200	22 x 25	1.5	9.4	7.2	3.6	77	28	15	PEH - 26KAB4120M--	
1500	22 x 30	1.8	11.5	8.8	4.4	59	20	11	PEH - 26KAC4150M--	
1500	25 x 25	1.7	9.8	7.5	3.7	62	23	16	PEH - 26KBB4150M--	
1800	22 x 25	1.7	9.6	7.3	3.7	62	28	14	PEH - 26KAB4180M--	
1800	25 x 35	2.5	14.1	10.7	5.3	36	14	9	PEH - 26KBD4180M--	
2200	22 x 30	2.0	11.7	8.9	4.5	49	22	11	PEH - 26KAC4220M--	
2200	25 x 25	1.9	10.0	7.6	3.8	52	24	15	PEH - 26KBB4220M--	
2200	30 x 25	2.1	9.8	7.4	3.7	48	22	19	PEH - 26KCB4220M--	
2700	25 x 35	2.5	14.1	10.7	5.3	36	14	9	PEH - 26KBD4270M--	
3300	30 x 25	2.4	10.0	7.6	3.8	40	22	18	PEH - 26KCB4330M--	
3900	25 x 35	2.8	14.3	10.9	5.4	30	14	9	PEH - 26KBD4390M--	
63 VDC (U_R)										
820	22 x 25	1.2	5.9	4.6	2.3	150	79	36	PEH - 26MAB382AM--	
1200	22 x 30	1.5	7.4	5.7	2.9	100	55	26	PEH - 26MAC412AM--	
1200	25 x 25	1.5	6.8	5.3	2.6	110	59	31	PEH - 26MBB412AM--	
1800	30 x 25	1.8	7.7	5.9	2.9	76	45	29	PEH - 26MCB418AM--	
2200	25 x 35	2.2	10.0	7.7	3.8	59	34	18	PEH - 26MBD422AM--	

* Maximum specified values

5 = Snap-in
6 = Radial lead

OPERATIONAL LIFE AND RIPPLE CURRENT

Operational life (L_{op}), at ambient temperature T_a and ripple current I_{AC} .

Example:

Article: PEH526KBB4220M3
Ambient temperature (T_a): 105°C
Ripple current, at 10kHz (I_{AC}): 7.6 A

$I_{RAC}(125°C, ≥5kHz) = 3.8 A$ (from data table)
→ $I_{AC} / I_{RAC}(125°C) = 2.0$

Operational life: Interpolation between the L_{op} -curves → $L_{op} \sim 8 kh$ (blue curves)

When the capacitor load is at 100Hz, use $I_{AC} / I_{RAC}(125°C, 100Hz)$ as input value to the diagram (see data table). At other frequencies use $I_{AC} / I_{RAC}(125°C, ≥5kHz) \times 1/Corr =$

Frequency correction factor, for ripple current (Corr):

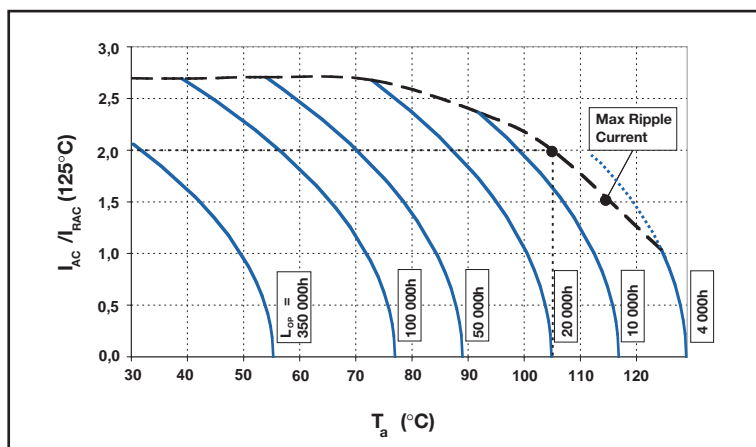

	FREQUENCY			
	300 Hz	1 kHz	5 kHz	100 kHz
Correction factor (Corr) (Typical value)	0.70	0.89	1.00	1.03

LEAKAGE CURRENT

Rated leakage current, I_{RL} (μ A)

Rated voltage, U_R (V)

Rated capacitance, C_R (μ F)

$I_{RL} = 0.01 \times C_R (\mu\text{F}) \times U_R (\text{V})$

CUSTOMER DESIGN

On request PEH526 can be designed in other capacitance values.

ORDERING INFORMATION

For further ordering information please see page 8.

Pos 1–20

P	E	H	5	2	6	K	A	C	4	1	5	0	M	3						
1	2	3	4	5	6	7	8	9	10	11	12	13	14	15	16	17	18	19	20	

Pos. 14: Capacitance tolerance M = -20 to +20%

Pos. 15 - 16: Pin configuration: 3 = three pin version, 08 = \varnothing 0.8 mm radial leads, 10 = \varnothing 1.0 mm radial leads

CASE CODE	AB	AC	BB	BD	CB	CD														
Weight approx (g)	12	14	19	24	24	34														
Standard box quantity	200	100	200	100	200	100														

THERMAL RESISTANCE FOR DIFFERENT CASE SIZES, AS A FUNCTION OF CASE AIR SPEED V

At ambient temperature $T_a = 40^\circ\text{C}$

Case		Air speed v											
		v=0,5m/s		v=1,0m/s		v=2,0m/s		v=3,0m/s		v=4,0m/s		v=5,0m/s	
		R_{thca}	R_{th}	R_{thca}	R_{th}	R_{thca}	R_{th}	R_{thca}	R_{th}	R_{thca}	R_{th}	R_{thca}	R_{th}
mm		$^\circ\text{C/W}$		$^\circ\text{C/W}$		$^\circ\text{C/W}$		$^\circ\text{C/W}$		$^\circ\text{C/W}$		$^\circ\text{C/W}$	
22 x 25	AB	24.3	25.1	19.1	20.0	14.8	15.7	13.2	14.1	11.4	12.3	10.3	11.1
22 x 30	AC	21.3	22.5	16.8	18.0	13.2	14.4	11.7	12.9	10.2	11.4	9.2	10.4
22 x 35	AD	19.1	20.5	15.1	16.6	11.9	13.4	10.7	12.1	9.4	10.8	8.5	9.9
22 x 40	AE	17.4	19.0	13.9	15.5	11.0	12.7	9.9	11.5	8.7	10.4	7.9	9.5
22 x 45	AF	16.1	17.6	12.9	14.4	10.4	11.8	9.3	10.8	8.3	9.7	7.5	9.0
22 x 50	AG	15.1	16.8	12.2	14.0	9.8	11.6	8.9	10.6	7.9	9.7	7.2	9.0
25 x 25	BB	21.9	22.8	17.2	18.1	13.4	14.3	11.8	12.6	10.2	11.1	9.2	10.0
25 x 30	BC	19.3	20.2	15.3	16.1	12.0	12.8	10.5	11.3	9.2	10.0	8.2	9.1
25 x 35	BD	17.2	18.2	13.7	14.7	10.8	11.8	9.6	10.6	8.4	9.4	7.6	8.6
25 x 40	BE	15.8	16.9	12.6	13.7	10.0	11.2	8.9	10.0	7.8	8.9	7.1	8.2
25 x 45	BF	14.7	16.2	11.8	13.3	9.4	10.9	8.4	9.9	7.4	8.9	6.8	8.3
25 x 50	BG	13.7	15.2	11.1	12.6	8.9	10.5	8.0	9.5	7.1	8.6	6.5	8.0
30 x 25	CB	18.9	19.5	14.9	15.5	11.7	12.3	10.0	10.6	8.7	9.3	7.8	8.4
30 x 30	CC	16.4	17.1	13.1	13.8	10.2	10.9	8.8	9.5	7.7	8.4	6.9	7.6
30 x 35	CD	14.8	15.6	11.8	12.6	9.3	10.1	8.0	8.9	7.0	7.9	6.3	7.2
30 x 40	CE	13.5	14.3	10.8	11.6	8.6	9.4	7.4	8.2	6.5	7.3	5.9	6.7
30 x 45	CF	12.5	13.3	10.0	10.9	8.0	8.9	7.0	7.8	6.2	7.0	5.6	6.5
30 x 50	CG	11.9	12.9	9.7	10.7	7.8	8.8	6.8	7.8	6.1	7.1	5.5	6.6
35 x 25	DB	16.5	17.0	13.1	13.6	10.5	11.0	8.6	9.1	7.5	8.0	6.7	7.2
35 x 30	DC	14.3	14.7	11.4	11.8	9.2	9.6	7.6	8.0	6.6	7.0	5.9	6.3
35 x 35	DD	12.9	13.4	10.3	10.8	8.3	8.8	6.9	7.4	6.0	6.5	5.4	5.9
35 x 40	DE	11.8	12.5	9.5	10.1	7.7	8.3	6.4	7.1	5.6	6.3	5.1	5.7
35 x 45	DF	10.9	11.6	8.8	9.5	7.1	7.9	6.0	6.7	5.3	6.0	4.8	5.5
35 x 50	DG	10.5	11.3	8.5	9.3	7.0	7.8	5.9	6.7	5.3	6.0	4.8	5.6
35 x 55	DH	9.6	10.3	7.8	8.5	6.4	7.1	5.4	6.1	4.8	5.5	4.4	5.1
35 x 60	DI	9.1	10.2	7.4	8.5	6.2	7.2	5.2	6.3	4.7	5.7	4.3	5.3
40 x 60	EI	8.2	9.0	6.7	7.6	5.5	6.3	4.6	5.5	4.1	5.0	3.8	4.7
40 x 70	EK	7.5	8.5	6.2	7.2	5.1	6.1	4.4	5.4	3.9	4.9	3.6	4.6
40 x 80	EM	7.0	8.3	5.9	7.2	4.9	6.2	4.2	5.5	3.8	5.1	3.5	4.8
40 x 100	EQ	6.4	8.2	5.4	7.2	4.6	6.3	4.1	5.8	3.7	5.4	3.4	5.2

 $(R_{thca} = \text{Thermal resistance between case and ambient})$